

MODULATOR BIAS CONTROLLER MBC-IQ-LAB

USER MANUAL

Version 1.0



Legal Notice.....	3
Disclaimers	3
About this Manual.....	3
Purpose.....	3
Audience	3
Prerequisites	3
Terms and Symbols in this Manual	3
Electrical Safety	4
Ventilation of the Board.....	4
Contacting Ixblue PSD:.....	4
General Information.....	5
Mach-Zehnder intensity modulators.....	5
Product Overview.....	7
Principle	7
Mechanical Dimensions	8
DC bias Cable.....	9
Getting started.....	9
Standard Accessories	9
Installation and first time operation	9
Operation.....	10
Selecting Auto/Manual mode	11
Adjusting dithering amplitude.....	11
Adjusting the photocurrent gain circuit.....	11



Legal Notice

Disclaimers

No warranty: This documentation is provided « as is » without any express or implied warranty of any kind.

Limitation of Liability: iXblue does not assume any liability arising out of the application or use of any products, or software described herein. In no event shall Photline be liable for any damage whatsoever (including, without limitation, consequential or incidental damages, damages for lot of profits, or otherwise) arising out of the use of the information provided in this documentation.

The contents of this publication have been carefully checked for accuracy. However, iXblue makes no warranty as to the completeness, correctness, or accuracy of the information contained within this documentation. In the interest of continued product improvement, Photline further reserves the right to make any change in any products describers herein without notice. This publication is subject to change without notice.

About this Manual

Purpose

The purpose of this instruction manual is to explain how to set up the MBC-DG-BOARD and to utilize the various features of the product.

Audience

This manual is designed to professionals with the necessary technical background and prerequisites needed to use fiber optics components, including Mach-Zehnder lithium niobate modulators, and the related test equipments and accessories.

Prerequisites

Reader is assumed to be familiar with fiber optics technology.

Terms and Symbols in this Manual

The following terms and symbols may appear throughout this manual :

WARNING : Warning statement identify conditions or practices that could result in injury or loss of life

CAUTION : Caution statement identify conditions or practices that could result in damage to this product or other property



Electrical Safety

	WARNING	Do not attempt to perform any servicing or maintenance To avoid personal injury, do not operate this instrument without the protective cover of the chassis. Do not make any service or maintenance of any kind to the system. Refer servicing only to authorized personnel from iXblue.
	WARNING	Operate under the proper environmental conditions. The board is designed for indoor use, only. To avoid the possibility of injury, do not expose this instrument to rain or excessive moisture. Do not operate the instrument in the presence of flammable gases or fumes.

Ventilation of the Board

	WARNING	Do not cover the board with any covering or overlay.
--	----------------	--

Contacting iXblue PSD:

For application oriented questions, for questions related to service, please contact iXblue PSD Besançon



General Information

Mach-Zehnder intensity modulators

Lithium niobate (LiNbO₃) Mach-Zehnder intensity modulators are external modulators that have been widely used since the mid-nineties, mostly in long haul optical networks for their ability to modulate optical signal from 1300 nm and 1550 nm laser diodes with short transition times and without chirp. Thanks to their broad wavelength performance, they currently also offer modulation solutions to 1064 nm and other near infrared lasers.

Mach-Zehnder modulators are two-wave interferometric devices and exhibit a sine transfer function (Figure 1). Although highly stable components, their operating point can suffer slow drift due to variations of external conditions and that drift may result in variations of key performances like extinction ratio.

In order to adjust the operating point of Mach-Zehnder modulators independently from the high frequency modulation signal applied, they can be designed with two sets of electrodes: one set of electrodes, the RF Electrodes, is used to apply the RF signal (PRBS data stream, analog signal, short pulses...). The second set of electrodes, the DC Bias Electrodes, is generally used to adjust with a controlled DC voltage the working point of the modulator. Figure 2 illustrate the typical electrode architecture of an IQ modulator with its internal structure. We will now give more details on the IQ modulator.

IQ modulator

An IQ modulator is basically a dual parallel Mach-Zehnder (DPMZ) modulator composed of four waveguides. The two first waveguides are linked together with input and output Y-junctions forming a first sub-Mach-Zehnder modulator (MZ₁). The two last waveguides are linked together with Y-junctions as well, forming a second sub-Mach-Zehnder modulator (MZ₂). Each output port of the Y-junctions is linked with a larger Y-junction. In conclusion, the IQ modulator structure is a Mach-Zehnder modulator with one sub-Mach-Zehnder modulator nested on each of his arms.

Electrodes are placed parallel to the waveguide arms. Two sets of high speed electrodes allow high speed modulation of the optical signal (one set per signal quadrature). Two sets of DC electrodes allow setting the nested modulator's polarization. A last set of DC electrodes allows adjusting the phase delay between the I & Q signals. In (D) QPSK / SSB / OFDM / QAM modulation formats, each DC voltage (DC₁ and DC₂) of the sub-MZ's is adjusted in order to introduce a phase shift equal to π , while the voltage applied to the phase difference between the two sub-MZ's is adjusted to introduce a phase shift of $\pi/2$.



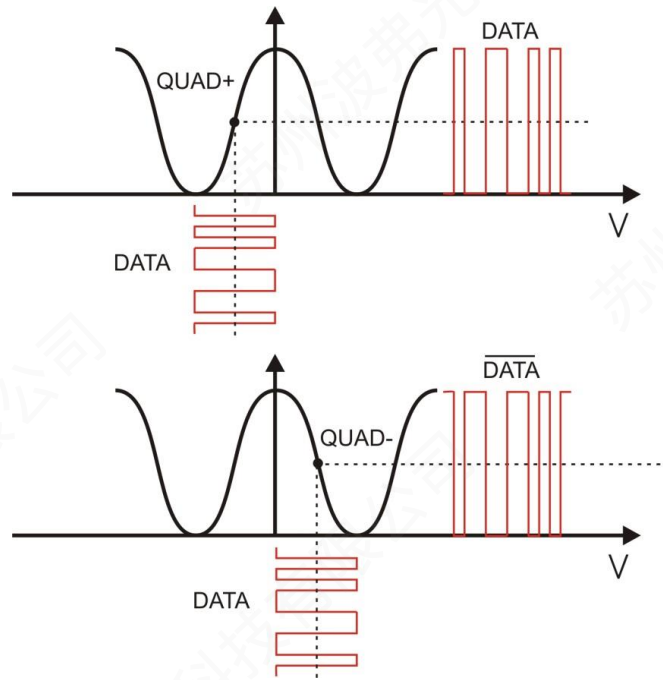

Figure 1 : transfer function of a Mach-Zehnder modulator and data output vs data input at QUAD+ and QUAD- operating point

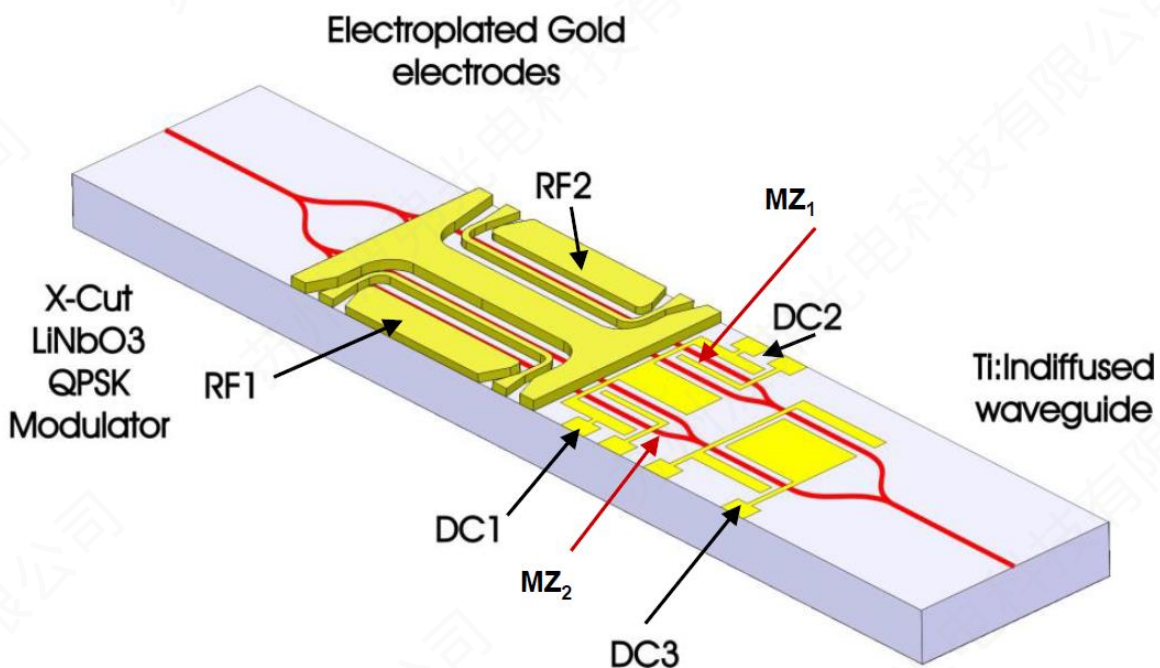

Figure 2: Simplified scheme of an IQ modulator with 2 separate sets of electrodes (DC and RF electrodes) for each signal quadrature (I & Q signals)



Product Overview

The MBC-IQ-Board is dedicated to operate with lithium niobate dual parallel Mach-Zehnder Modulators. The equipment is an automatic bias voltage controller designed to stabilize the operating point of the two sub-MZM of a dual parallel MZM. It continuously adjusts the sub-MZM DC electrode bias voltage (DC1 and DC2 in figure 2 above) based on real time monitoring of the sub-MZM polarization set points through digital signal processing.

The MBC-IQ-Board algorithm sets the sub-MZM at MIN point and the main MZM at QUAD+ or QUAD- point.

Principle

The principle is here shown for a single MZM:

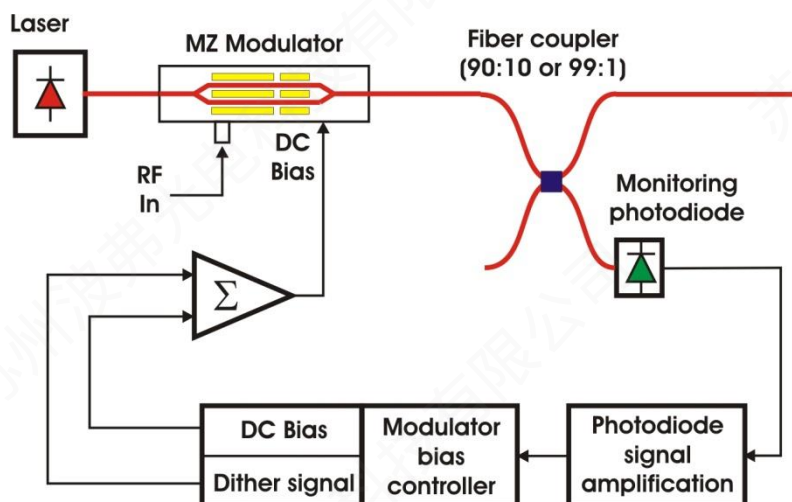

Figure 3: basic scheme of a modulation set-up including a modulator bias controller and an external monitoring photodiode

A Mach-Zehnder modulator is illuminated by a laser at the optical input. The data stream is applied to the RF electrodes. At the output of the MZ modulator, a fiber coupler with a strong imbalance (10:90 or 1:99) allows to detect a small portion of the transmitted light with a monitoring photodiode. The signal is amplified and processed in order to control the stability of the operating point. Any deviation is compensated by a corrected value of the electrical bias voltage applied by the feedback loop in order to maintain the operating point at the desired position.

The principle of operation of the MBC is based on the generation of a very low frequency and low amplitude electrical signal (dither signal), which is summed to the DC bias voltage. Any deviation from the working point creates harmonics that can be measured and compared by frequency analysis and by signal processing carried out by a specific algorithm, developed by iXblue, in order to retrieve the sign and the amplitude of the deviation.

When using an IQ modulator, DC1 and DC2 are polarized in MIN. And DC3 is polarized in QUAD+ or QUAD-.



Mechanical Dimensions

221mm x 221mm x 44mm

MBC LAB:

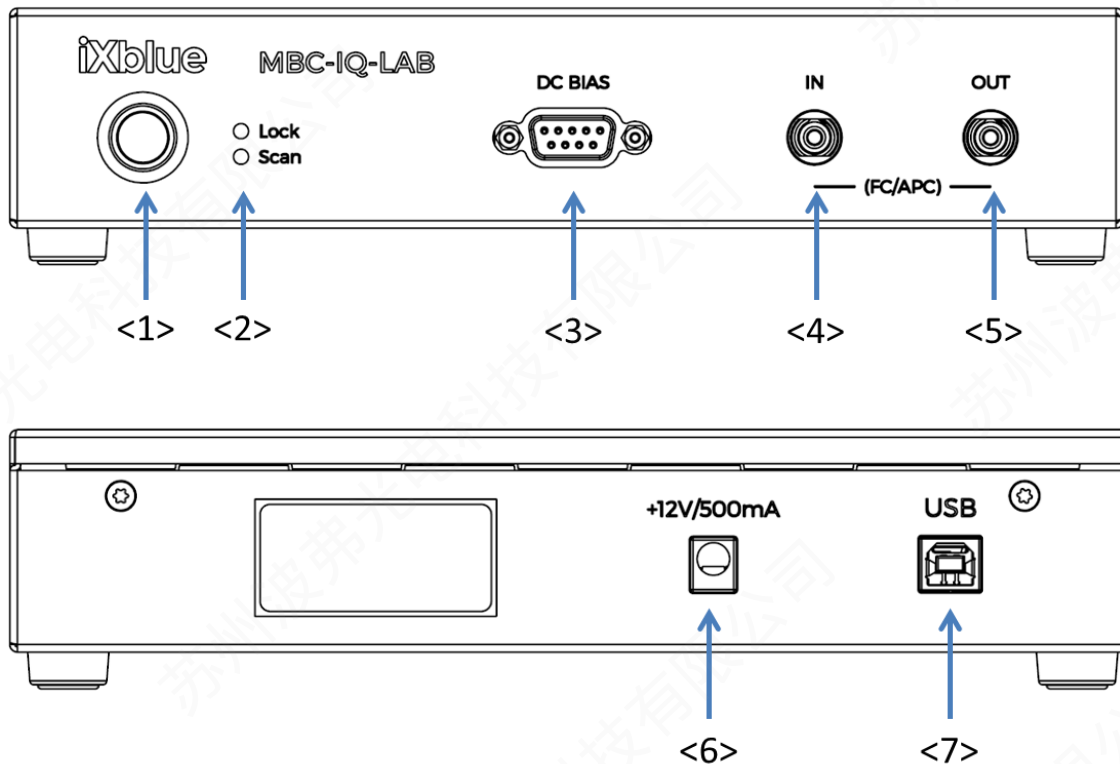

<1> Power button

<2> Control LED

Lock: MBC is locked to the fixed point (still active when laser light is off)
Scan: MBC is performing a scan. If flashing, no signal detected.

<3> Bias Modulator connector (BNC)

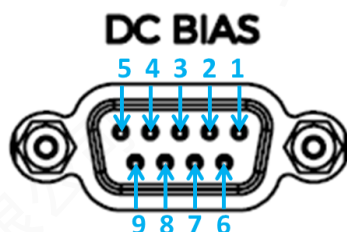

1 DC1+	6 DC1-
2 GND	7 GND
3 DC2+	8 DC2-
4 GND	9 DC3-
5 DC3+	

<4> Input Optical Connector

<5> Output optical connector (coupler option)

<6> Power supply connector (Jack 3.5mm, 12V 500mA)

<7> USB connector



iXblue S.A.S.
Phonic Solutions Business Unit
3, rue Sophie Germain, TEMIS
25000 Besançon, France

T. : +33 3 81 85 31 80
F. : +33 3 81 85 15 57
www.photonics.ixblue.com

DC bias Cable

The cable is built to be used on iXblue modulator. It has the following pinning:

N°	Color	Function
1	White	DC1+
2	Black	GND
3	Red	DC2+
4	Green	DC3+

Getting started

Standard Accessories

User Manual
Interface User Manual
Cord Kit
USB Cord

Installation and first time operation

Proceed as follow to install the MBC-IQ-LAB:

- Set MBC LAB on a flat stable surface
- Connect the power supply plug-in to the power supply connector <6>
- Connect the modulator optical output through a tap coupler for "no coupler option", directly for "coupler option" to "In"-connector of the MBC-IQ-LAB(<4>).See optical connection schemes bellow.
- Connect the DC cable to "DC-Bias" (<3>) and wires to the bias electrode of the modulator. Black (Ground), White (DC1+), Red (DC2+) and Green (DC3+).
- Switch on the laser to illuminate the modulator at the desired optical power level
- Power ON the MBC-IQ-LAB <1>
- A procedure of initialization by scanning the Vbias range from $-13.5V$ to $+13.5V$ will start to adjust automatically the operating point by use of the initial conditions
- After stabilization, the RF signal can be applied and the parameters of the MBC can be modified.
- Any change of the dither frequency results in a new search of the operating point by scanning of the bias voltage from $-13.5V$ to $+13.5V$.



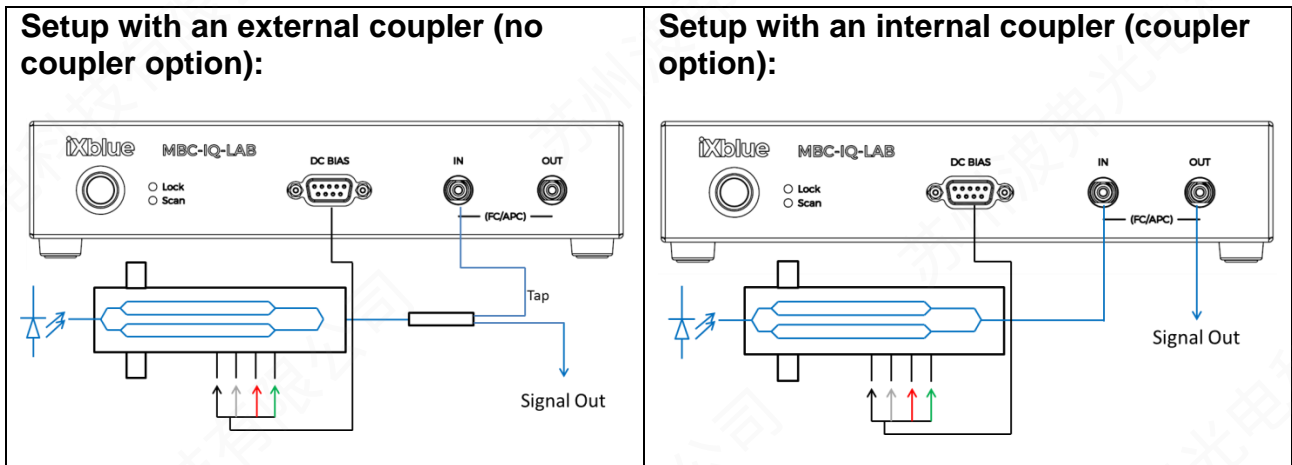

The optical signal processing in the MBC is such that the value of the RF amplitude voltage is limited. The limit is $0.75V\pi$ and the MBC will not work correctly if the RF signal with larger amplitude is applied to the modulator.

A $0.75V\pi$ amplitude is equivalent to a $1.5V\pi$ peak-to-peak value and the majority of the applications operate with a lower RF signal: typically $0.5V\pi$ amplitude (or $2V\pi$ peak-to-peak). Thus, in spite of that restriction, the MBC will operate correctly with most of the application.

Modulator bias stability in industrial environment

Due to its detection sensitivity and the low level of signal applied to the modulator. The MBC IQ LAB may encounter issues in industrial environment (electrical field strength from 10V/m and beyond). It can be observed in manual mode, if one can detect fast contrast variations of a few dB, it may be a sign of electromagnetic perturbation. To mitigate this effect, one needs to remove the plastic sheet of the furnished cable near the cable end (2), and connect it to a metal plate with a flange. The modulator package need also to be fixed (1) on the same metal plate. The shorter the shielding connection is, the better will be the result.

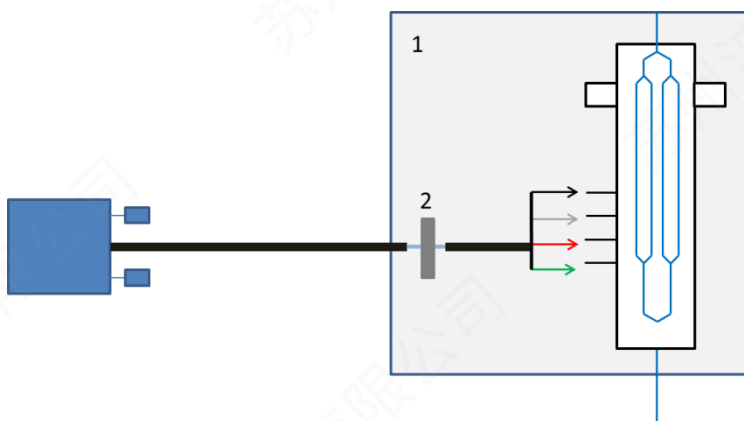

Operation

For more information on the way to set parameters, please refer to the GUI interface handbook.



Selecting Auto/Manual mode

One can choose between two operation modes: AUTO or MANUAL.

In AUTO mode, the board searches the bias value corresponding to the selected transfer level.

In MANUAL mode, one sets the DC bias value, and no dither is applied to DC Bias.

Adjusting dithering amplitude

The MBC allows the user to adjust the dithering amplitude between 10 mV and 1 V. This feature proves especially useful to optimize the overall performance of the MBC and to adapt to various conditions such as modulator V_{pi} or photodiode response. MBC IQ LAB dither amplitude is set at 100mVpp (2% of modulator V_{pi}). Increasing dither, in general by 20 to 50mVpp may help for feedback loop stabilization at low optical power (-20dBm on photodiode for example).

After modifying this parameter, one must do a scan restart.

Adjusting the photocurrent gain circuit

The MBC IQ offers 127 different gain values for the photocurrent circuit so as to adapt to the largest variety of applications and to offer the widest dynamic range for the input photocurrent. In certain conditions, high gain may create loop oscillations.

After modifying this parameter, one must do a scan restart.

