

The **OPTIPHASE PZ1** is the high-speed member of our family of fiber stretchers. It is a fiber wound piezoelectric element for use in a wide range of optical interferometric measurement and sensing system applications. Typical uses include open loop demodulation, sensor simulation, variable optical delay, general purpose fiber interferometry and large angle modulation of interferometric phase.

Optiphase's expertise in the design, manufacture and use of all-fiber interferometers has produced a unique multi-layer winding approach resulting in an enhanced modulation function while maintaining a

high operational frequency [see charts]. PZ1 Fiber Stretchers are available with SM, commercial PM [PANDA or Bowtie] or RC [SM Reduced Cladding] fiber types.

The PZ1 delivers a high performance to cost ratio, exceeding all other known competitive devices. The compact and low-profile form factor makes the PZ1 easily configurable into small spaces. In addition, our fiber stretchers are unique in that they do not require proprietary drivers. For most low voltage applications (< ± 15V) our stretchers can be driven by standard electronics such as signal generators, op-amps or other laboratory equipment without modification. For more information on how to drive PZ1 stretchers see page 2.

FEATURES & BENEFITS

- High Speed
- Low Cost
- Compact package
- SM, PM or RC fiber
- Multiple termination choices
- Unique multi-layer winding
- Can be driven with general purpose electronics

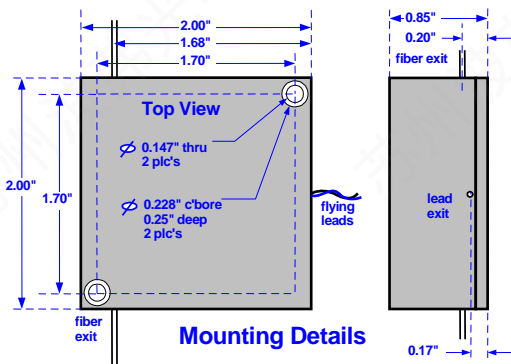

The PZ1's low profile and small footprint makes it easy to integrate into virtually any system device. Several termination options are available, making set-up and use quick and easy.

SPECIFICATIONS

PZ1 FIBER STRETCHER	SM FIBER 4-LAYER	PM FIBER 4-LAYER	PM FIBER 1-LAYER	RC FIBER 4-LAYER
Operational Wavelengths	780 - 1625 nm	780 to 1625 nm	780 to 1625 nm	780 to 1625 nm
Modulation Constant [< 5 KHz]	$1.3 / \lambda$ radians/V where λ wavelength in μm Example: $=1$ radian/V @ $1.3 \mu\text{m}$	$1.3 / \lambda$ radians/V where λ wavelength in μm Example: $=1.7$ radians/V @ $0.78 \mu\text{m}$	$0.325 / \lambda$ radians/V where λ wavelength in μm Example: $=0.2$ radians/V @ $1.5 \mu\text{m}$	$1.9 / \lambda$ radians/V where λ wavelength in μm Example: $=1.45$ radians/V @ $1.3 \mu\text{m}$
Fiber Stretch	$0.14 \mu\text{m} / \text{Volt}$	$0.14 \mu\text{m} / \text{Volt}$	$0.035 \mu\text{m} / \text{Volt}$	$0.21 \mu\text{m} / \text{Volt}$
Optical Path Displacement [n=1]	$0.2 \mu\text{m} / \text{Volt}$	$0.2 \mu\text{m} / \text{Volt}$	$0.05 \mu\text{m} / \text{Volt}$	$0.3 \mu\text{m} / \text{Volt}$
Time Delay	$0.0007 \text{ ps} / \text{Volt}$	$0.0007 \text{ ps} / \text{Volt}$	$0.00017 \text{ ps} / \text{Volt}$	$0.001 \text{ ps} / \text{Volt}$
Fiber Length	12.3 meters inclusive	12.3 meters inclusive	5 meters inclusive	17 meters inclusive
Fiber Wind	4-layer	4-layer	The 1-layer design preserves a high polarization extinction ratio reducing the modulation constant.	4-layer
Fiber Type [See chart pg. 2]	SM [various] 245 μm jacket	PM [various] 245 μm jacket		RC SMF [80/165] 165 μm jacket
Extinction Ratio	Not applicable	$\leq -20 \text{ dB typ} / \text{Near IR} \leq -16$ Bowtie	$\leq 24 \text{ dB bare leads}; \leq 22 \text{ dB with connectors}$	Not applicable
Optical Loss		$\leq 0.5 \text{ dB}$, typical 0.2 dB (excluding connectors)		
Maximum Voltage Range		$\pm 500\text{V}$ [off resonance, 1000V P-P]		
Frequency Range		See chart page 2, specified at 1550 nm		
Linearity error (typ)		Drive $< 30\text{V p-p}$: $< 0.5\%$ Drive $< 100 \text{ V p-p}$: $< 1\%$ Full scale: $< 3\%$		
Impedance [below resonance]		Capacitance 2 nF nominal, floating		
Electrical Interface		18 inches, flying leads, #30		
Fiber Leads		1 meter, 900 μm loose tube		
Drive Polarity		White wire positive for positive stretch		
Connector Options		Bare fiber, FC/PC or FC/APC		
Operational Temperature Range		0° to 70° C		Made in U.S.A.
Dimensions Weight		2.0" W x 2.0" D x 0.85" H 5.7 ounces / 162 grams		

PZ1 Modulation Characteristic Over Frequency Optical Path Displacement per applied volt (n = 1)

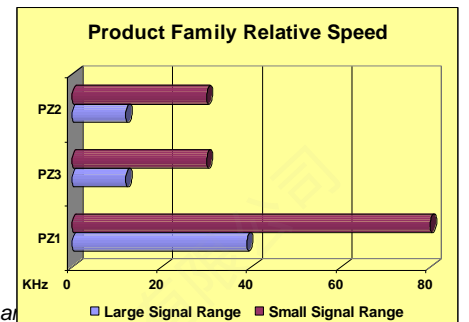
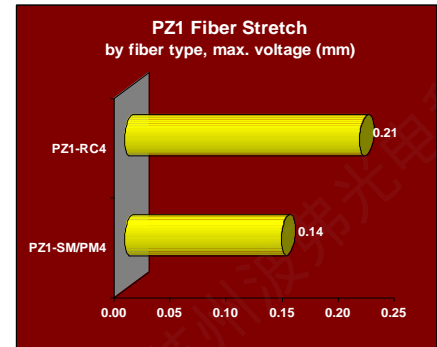
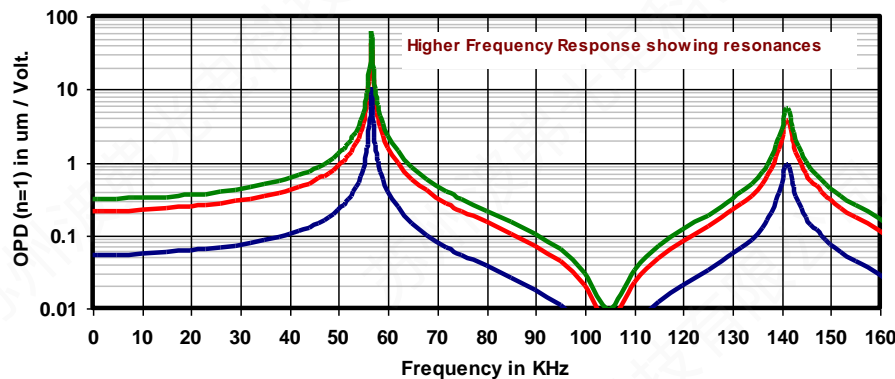
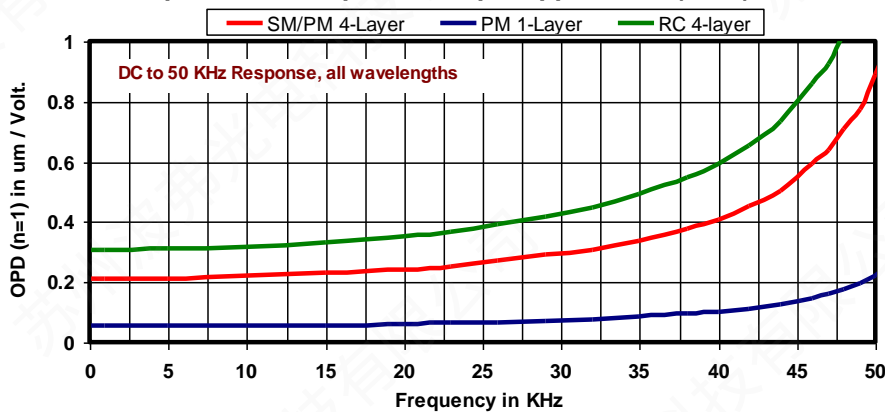

Small Signal = Frequencies extending past resonance, but at reduced modulation levels

PZ1 Fiber Stretcher Models

Model	Description
PZ1-SMF4-E	High-speed stretcher, 4-layer SMF28 fiber, bare leads, enclosed
PZ1-SMF4-PC-E	High-speed stretcher, 4-layer SMF28 fiber, FC/PC connectors, enclosed
PZ1-SMF4-APC-E	High-speed stretcher, 4-layer SMF28 fiber, FC/APC connectors, enclosed
PZ1-SM4-E-XXX	High-speed stretcher, 4-layer SM fiber, bare leads, enclosed
PZ1-SM4-PC-E-XXX	High-speed stretcher, 4-layer SM fiber, FC/PC connectors, enclosed
PZ1-SM4-APC-E-XXX	High-speed stretcher, 4-layer SM fiber, FC/APC connectors, enclosed
PZ1-PM4-E-XXX	High-speed stretcher, 4-layer PM fiber, bare leads, enclosed
PZ1-PM4-PC-E-XXX	High-speed stretcher, 4-layer PM fiber, FC/PC connectors, enclosed
PZ1-PM4-APC-E-XXX	High-speed stretcher, 4-layer PM fiber, FC/APC connectors, enclosed
PZ1-PM1-E-XXX	High-speed stretcher, 1-layer PM fiber, bare leads, enclosed
PZ1-PM1-PC-E-XXX	High-speed stretcher, 1-layer PM fiber, FC/PC connectors, enclosed
PZ1-PM1-APC-E-XXX	High-speed stretcher, 1-layer PM fiber, FC/APC connectors, enclosed
PZ1-RC4-E	High-speed stretcher, 4-layer RC fiber, bare leads, enclosed
PZ1-RC4-PC-E-XXX	High-speed stretcher, 4-layer RC fiber, FC/PC connectors, enclosed
PZ1-RC4-APC-E-XXX	High-speed stretcher, 4-layer RC fiber, FC/APC connectors, enclosed

Designed for Bipolar Drive

Optiphase fiber stretchers are designed to operate with a bipolar voltage drive. This is unique capability offers significantly greater convenience when compared to other approaches that mandate unipolar operation only with an offset voltage drive.

How to drive PZ1 stretchers

The equivalent circuit for the PZ1 fiber stretcher is shown below. At frequencies sufficiently below the first resonance (dc - 40 KHz) the effective impedance is capacitive, defined by $C0+C1+C2$, being approximately 2 nF. At 40 KHz, the magnitude of the impedance of this capacitance is 2000 ohms. Most laboratory equipment or circuitry can be used to drive this load with no modifications.

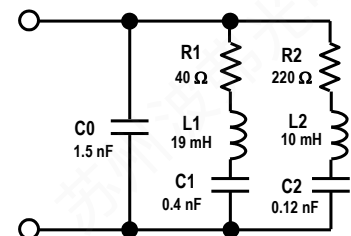

PZ1 Series Equivalent Impedance

DC - 10 KHz is approx $C0 + C1 + C2$ (= 2 nF)
First Resonance (57 KHz) defined by R1, C1, L1
Second Resonance (140 KHz) defined by R2, C2, L2

Trademarks are property of their respective manufacturers.

Part No. Designation and Fiber Types Used				
λ range (nm):	780-900	950-1200	1260-1400	1450-1625
XXX =	850	980	131	155
Y = P for Panda; B for Bowtie				
SM / SMF	Corning HI-780	Corning HI-980	Corning SMF28e+	
RC	NA	NA	Draka Elite 80 um BendBright-XS	
PM-Panda (4-layer)	Corning PM 850	Corning PM 980	NA	
PM-Panda (1-layer)	Same as above		Corning PM 1300	Corning PM 1550
PM-Bowtie	Fibercore HB800	Fibercore HB1000	Fibercore HB1250 ¹	Fibercore HB1500 ¹

¹ 4-layer Bowtie Extinction Ratio: -16dB

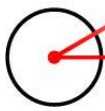

High-efficiency Fiber Stretcher

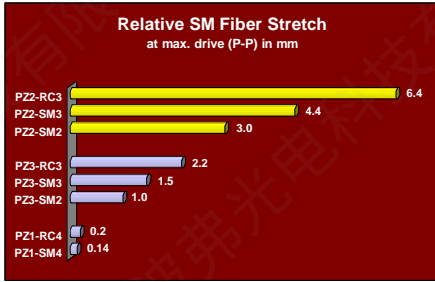

The **OPTIPHASE PZ2** provides the most extensive stretch of our stretcher product family. It is a fiber wound piezoelectric element for use in a wide range of optical interferometric measurement and sensing system applications. Typical uses include open loop demodulation, sensor simulation, white-light scanning interferometry and large angle modulation of interferometric phase. The PZ2 is ideal for use in OCT [Optical Coherence Tomography] and OCDR [Optical Coherence Domain Reflectometry] applications requiring scattering or boundary definition measurements.



Optiphase's expertise in the design, manufacture and use of all-fiber interferometers has produced a unique multi-layer winding approach resulting in an enhanced modulation function while maintaining a high operational frequency [see charts]. PZ2 Fiber Stretchers are available with SM, commercial PM [PANDA or Bowtie] or RC [SM Reduced Cladding] fiber types. Fiber stretchers with connectors are housed in an enclosure, making set-up and use quick and easy. These fiber stretchers are unique in that they do not require proprietary drivers. For most low voltage applications (< ± 15V) our stretchers can be driven by standard electronics such as signal generators, op-amps or other laboratory equipment without modification. For more information on how to drive PZ2 stretchers see page 2.

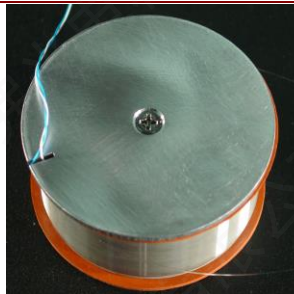
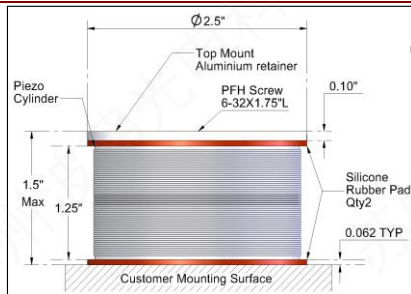

Bare Lead Fiber Stretcher with Mounting Kit

Fiber stretchers with bare leads are not enclosed and include a convenient mounting kit consisting of a top mount aluminum retainer and two silicone rubber pads. The Mounting Kit includes top or bottom mount.

SPECIFICATIONS

PZ2 FIBER STRETCHER	SM FIBER 2-LAYER	SM FIBER 3-LAYER	PM FIBER 2-LAYER	PM FIBER 3-LAYER	RC FIBER 3-LAYER
Operational Wavelengths	780 - 1625 nm	780 - 1625 nm	780 to 1625 nm	780 to 1625 nm	780 to 1625 nm
Modulation Constant [< 5 KHz]	35.4 / λ radians/V where λ wavelength in μm Example: = 22.8 radians/V @ 1.550 μm	51 / λ radians/V where λ wavelength in μm Example: = 32.9 radians/V @ 1.550 μm	35.4 / λ radians/V where λ wavelength in μm Example: = 45.3 radians/V @ 0.78 μm	51 / λ radians/V where λ wavelength in μm Example: = 65.3 radians/V @ 0.78 μm	74.3 / λ radians/V where λ wavelength in μm Example: = XX radians/V @ 1.550 μm
Fiber Stretch	3.8 μm / Volt	5.5 μm / Volt	3.8 μm / Volt	5.5 μm / Volt	8.0 μm / Volt
Optical Path Displacement	5.6 μm / Volt	8.1 μm / Volt	5.6 μm / Volt	8.1 μm / Volt	11.8 μm / Volt
Time Delay	0.019 ps / Volt	0.027 ps / Volt	0.019 ps / Volt	0.027 ps / Volt	0.039 ps / Volt
Fiber Length	40 meters inclusive	60 meters inclusive	40 meters inclusive	60 meters inclusive	82 meters inclusive
Fiber Wind	2-layer	3-layer	2-layer	3-layer	3-layer
Fiber Type [See chart pg. 2]	SM [various] 245 μm jacket		PM [various] 245 μm jacket		RC SMF [80/165] 165 μm jacket
Extinction Ratio	Not applicable		≤ -20 dB typical		Not applicable
Optical Loss	≤ 0.5 dB, typical 0.2 dB (excluding connectors)				
Maximum Voltage Range	$\pm 400\text{V}$ up to 300 Hz, then derate -6 dB per octave				
Frequency Range	See chart page 2, specified at 1550 nm				
Linearity error (typ)	Drive $< 30\text{V}$ p-p: $< 0.5\%$ Drive $< 100\text{V}$ p-p: $< 1\%$ Full scale: $< 3\%$				
Impedance [below resonance]	Capacitance 92 nF nominal, floating				
Electrical Interface	Open stretcher: 18 inches, flying leads, #30 Enclosed stretcher: Isolated BNC				
Drive Polarity	Open stretcher: blue wire positive for positive stretch Enclosed stretcher: Positive voltage for positive stretch				
Connector Options	Open stretcher: 1 meter bare fiber leads Enclosed stretcher: FC/PC or FC/APC				
Operational Temperature Range	0° to 70°C				
DIMENSIONS & WEIGHT					
Open Fiber Stretcher	2.5" Diameter x 1.5" High [nominal without mounting surface]; 80 grams				
Enclosed Fiber Stretcher	Enclosure: 4" W x 6" L x 1.75" H; 16 oz; Mount hole centers (4 places) at "3.5" X" "6.375", hole size 0.156" diameter				
MOUNTING KIT INCLUDED WITH OPEN STRETCHER					
Top Mount Aluminum Retainer	2.5 inch diameter, 0.1 inch thickness [qty 1]				
Silicone Rubber Pads	2.5 inch diameter, 0.0625 inch thickness [qty 2]				
Screw	#6-32 flathead screw, cut to 0.93 inch or less [qty 1]				
					Made in U.S.A.

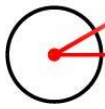

PZ2 Modulation Characteristic Over Frequency Optical Path Displacement per applied volt (n = 1)

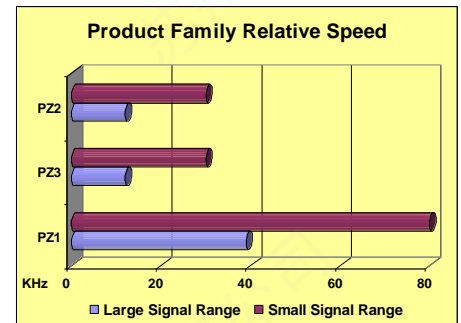
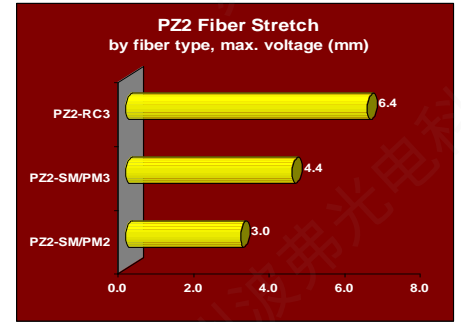
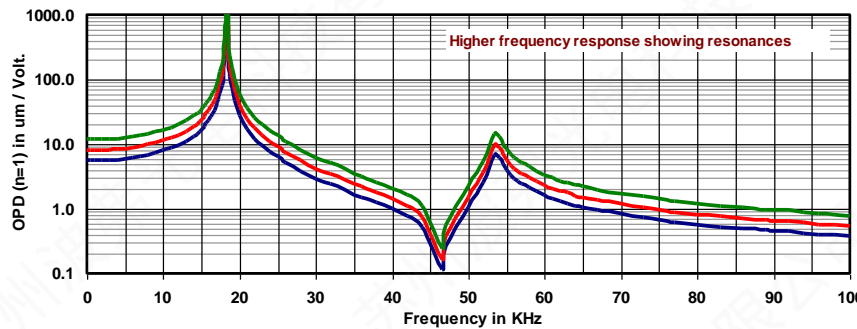
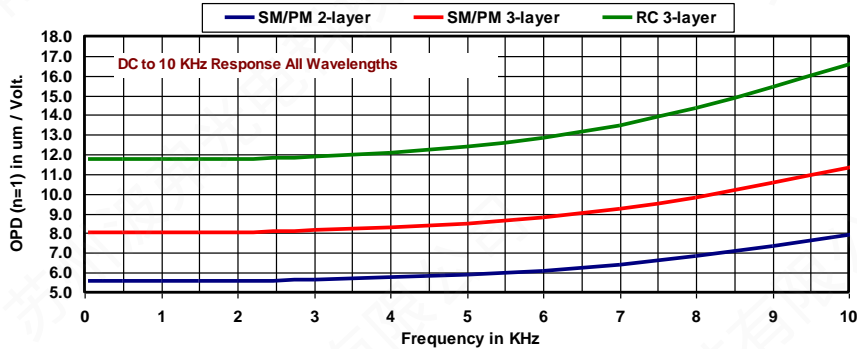

Large Signal = 70% of 1st Resonance Operation
Small Signal = Frequencies extending past resonance, but at reduced modulation levels

PZ2 Fiber Stretcher Models

Model	Description
PZ2-SMF2-O	High-efficiency stretcher, 2-layer SMF28 fiber, bare leads, open, mounting kit
PZ2-SMF2-PC-E	High-efficiency stretcher, 2-layer SMF28 fiber, FC/PC connectors, enclosed
PZ2-SMF2-APC-E	High-efficiency stretcher, 2-layer SMF28 fiber, FC/APC connectors, enclosed
PZ2-SM2-O-XXX	High-efficiency stretcher, 2-layer SM fiber, bare leads, open, mounting kit
PZ2-SM2-PC-E-XXX	High-efficiency stretcher, 2-layer SM fiber, FC/PC connectors, enclosed
PZ2-SM2-APC-E-XXX	High-efficiency stretcher, 2-layer SM fiber, FC/APC connectors, enclosed
PZ2-SMF3-O	High-efficiency stretcher, 3-layer SMF28 fiber, bare leads, open, mounting kit
PZ2-SMF3-PC-E	High-efficiency stretcher, 3-layer SMF28 fiber, FC/PC connectors, enclosed
PZ2-SMF3-APC-E	High-efficiency stretcher, 3-layer SMF28 fiber, FC/APC connectors, enclosed
PZ2-SM3-O-XXX	High-efficiency stretcher, 3-layer SM fiber, bare leads, open, mounting kit
PZ2-SM3-PC-E-XXX	High-efficiency stretcher, 3-layer SM fiber, FC/PC connectors, enclosed
PZ2-SM3-APC-E-XXX	High-efficiency stretcher, 3-layer SM fiber, FC/APC connectors, enclosed
PZ2-PM2-O-XXX	High-efficiency stretcher, 2-layer PM fiber, bare leads, open, mounting kit
PZ2-PM2-PC-E-XXX	High-efficiency stretcher, 2-layer PM fiber, FC/PC connectors, enclosed
PZ2-PM2-APC-E-XXX	High-efficiency stretcher, 2-layer PM fiber, FC/APC connectors, enclosed
PZ2-PM3-O-XXX	High-efficiency stretcher, 3-layer PM fiber, bare leads, open, mounting kit
PZ2-PM3-PC-E-XXX	High-efficiency stretcher, 3-layer PM fiber, FC/PC connectors, enclosed
PZ2-PM3-APC-E-XXX	High-efficiency stretcher, 3-layer PM fiber, FC/APC connectors, enclosed
PZ2-RC3-O-XXX	High-efficiency stretcher, 3-layer RC fiber, bare leads, open, mounting kit
PZ2-RC3-PC-E-XXX	High-efficiency stretcher, 3-layer RC fiber, FC/PC connectors, enclosed
PZ2-RC3-APC-E-XXX	High-efficiency stretcher, 3-layer RC fiber, FC/APC connectors, enclosed

Designed for Bipolar Drive

Optiphase fiber stretchers are designed to operate with a bipolar voltage drive. This is unique capability offers significantly greater convenience when compared to other approaches that mandate unipolar operation only with an offset voltage drive.

How to drive PZ2 stretchers

The equivalent circuit for the PZ2 fiber stretcher is shown below. At frequencies sufficiently below the first resonance (dc - 10 KHz) the effective impedance is capacitive, defined by C0+C1+C2, being approximately 92 nF. At 10 KHz, the magnitude of the impedance of this capacitance is 175 ohms. Most laboratory equipment or circuitry can be used to drive this load with no modifications.

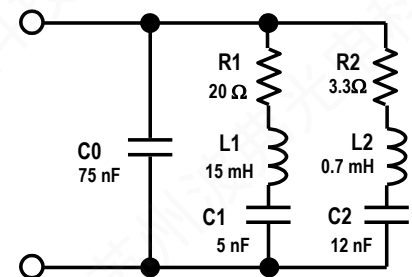

PZ2 Series Equivalent Impedance

DC - 10 KHz is approx C0 + C1 + C2 (= 92 nF)
First Resonance (18 KHz) defined by R1, C1, L1
Second Resonance (110 KHz) defined by R2, C2, L2

Part No. Designation and Fiber Types Used

λ range (nm):	780-900	950-1200	1260-1400	1450-1625
XXX =	850	980	131	155
Y =	P for PANDA; B for Bowtie			
SM / SMF	Corning HI-780	Corning HI-980	Corning SMF28e+	
RC	NA	NA	Draka Elite 80 um BendBright-XS	
PM-Panda	Corning PM 850	Corning PM 980	Corning PM 1300	Corning PM 1550
PM-Bowtie	Fibercore HB800	Fibercore HB1000	Fibercore HB1250	Fibercore HB1500

Trademarks are property of their respective manufacturers.

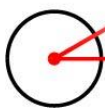

Mid-range Fiber Stretcher

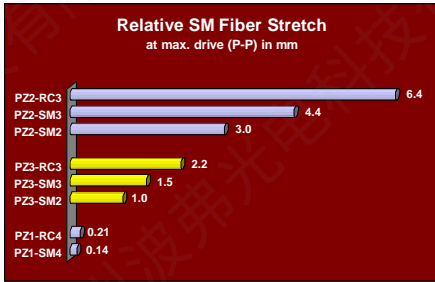

The **OPTIPHASE PZ3** is the mid-range member of our family of fiber stretchers. It is a fiber wound piezoelectric element for use in a wide range of optical interferometric measurement and sensing system applications. Typical uses include open loop demodulation, sensor simulation, variable optical delay, general purpose fiber interferometry and large angle modulation of interferometric phase.

Optiphase's expertise in the design, manufacture and use of all-fiber interferometers has produced a unique multi-layer winding approach resulting in an enhanced modulation function while maintaining a high operational frequency [see charts]. PZ3 Fiber



Stretchers are available with SM, commercial PM [PANDA or Bowtie] or RC [SM Reduced Cladding] fiber types. Fiber stretchers with connectors are housed in an enclosure, making set-up and use quick and easy. These fiber stretchers are unique in that they do not require proprietary drivers. For most low voltage applications (< ± 15V) our stretchers can be driven by standard electronics such as signal generators, op-amps or other laboratory equipment without modification. For more information on how to drive PZ3 stretchers see page 2.

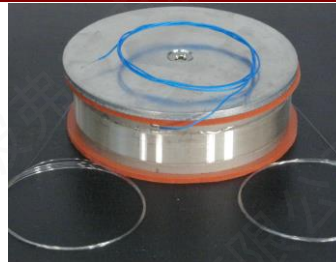
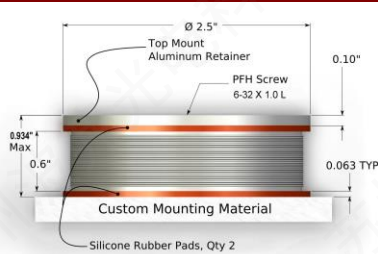

Bare Lead Fiber Stretcher with Mounting Kit

Fiber stretchers with bare leads are not enclosed and include a convenient mounting kit consisting of a top mount aluminum retainer and two silicone rubber pads. The Mounting Kit includes top or bottom mount.

SPECIFICATIONS

PZ3 FIBER STRETCHER	SM FIBER 2-LAYER	SM FIBER 3-LAYER	PM FIBER 2-LAYER	PM FIBER 3-LAYER	RC FIBER 3-LAYER
Operational Wavelengths	780 - 1625 nm	780 - 1625 nm	780 to 1625 nm	780 to 1625 nm	780 to 1625 nm
Modulation Constant [< 5 KHz]	$12.2 / \lambda$ radians/V where λ wavelength in μm Example: = 7.9 radians/V @ 1.550 μm	$17.7 / \lambda$ radians/V where λ wavelength in μm Example: = 11.4 radians/V @ 1.550 μm	$12.2 / \lambda$ radians/V where λ wavelength in μm Example: = 15.6 radians/V @ 0.78 μm	$17.7 / \lambda$ radians/V where λ wavelength in μm Example: = 11.4 radians/V @ 1.550 μm	$26 / \lambda$ radians/V where λ wavelength in μm Example: = 16.8 radians/V @ 1.550 μm
Fiber Stretch	1.3 μm / Volt	1.9 μm / Volt	1.3 μm / Volt	1.9 μm / Volt	2.8 μm / Volt
Optical Path Displacement	1.9 μm / Volt	2.7 μm / Volt	1.9 μm / Volt	2.7 μm / Volt	4.0 μm / Volt
Time Delay	0.0064 ps / Volt	0.0093 ps / Volt	0.0064 ps / Volt	0.0093 ps / Volt	0.014 ps / Volt
Fiber Length	15 meters inclusive	22 meters inclusive	15 meters inclusive	22 meters inclusive	30 meters inclusive
Fiber Wind	2-layer	3-layer	2-layer	3-layer	3-layer
Fiber Type [See chart pg. 2]	SM [various] 245 μm jacket		PM [various] 245 μm jacket		RC SMF [80/165] 165 μm jacket
Extinction Ratio	Not applicable		≤ -20 dB typical		Not applicable
Optical Loss	≤ 0.5 dB, typical 0.2 dB (excluding connectors)				
Maximum Voltage Range	± 400 V up to 300 Hz, then derate -6 dB per octave				
Frequency Range	See chart page 2, specified at 1550 nm				
Linearity error (typ)	Drive < 30 V p-p: $< 0.5\%$ Drive < 100 V p-p: $< 1\%$ Full scale: $< 3\%$				
Impedance [below resonance]	Capacitance 42 nF nominal, floating				
Electrical Interface	Open stretcher: 18 inches, flying leads, #30 Enclosed stretcher: Isolated BNC				
Drive Polarity	Open stretcher: blue wire positive for positive stretch Enclosed stretcher: Positive voltage for positive stretch				
Connector Options	Open stretcher: 1 meter bare fiber leads Enclosed stretcher: FC/PC or FC/APC				
Operational Temperature Range	0° to 70° C				
DIMENSIONS & WEIGHT					
Open Fiber Stretcher	2.5" Diameter x 0.9" High [nominal without mounting surface, height guaranteed < 0.934 "]; 60 grams				
Enclosed Fiber Stretcher	Enclosure: 4" W x 6" L x 1.75" H; 16 oz; Mount hole centers (4 places) at "3.5" X" "6.375", hole size 0.156" diameter				
MOUNTING KIT INCLUDED WITH OPEN STRETCHER					
Top Mount Aluminum Retainer	2.5 inch diameter, 0.1 inch thickness [qty 1]				
Silicone Rubber Pads	2.5 inch diameter, 0.0625 inch thickness [qty 2]				
Screw	#6-32 flathead screw, cut to 0.93 inch or less [qty 1]				
					Made in U.S.A.

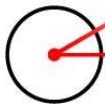

PZ3 Modulation Characteristic Over Frequency
Optical Path Displacement per applied volt (n = 1)

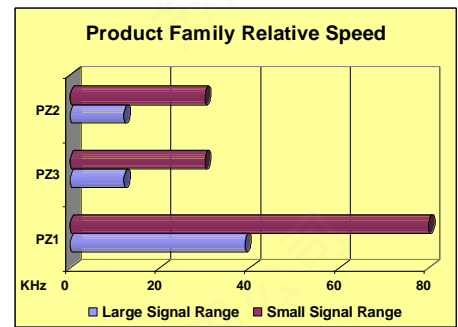
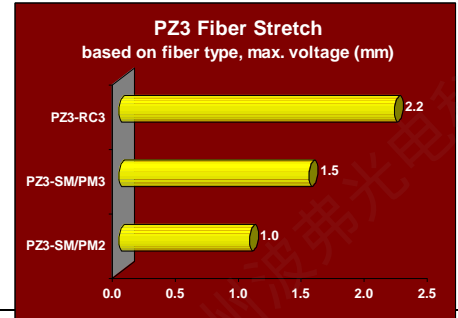
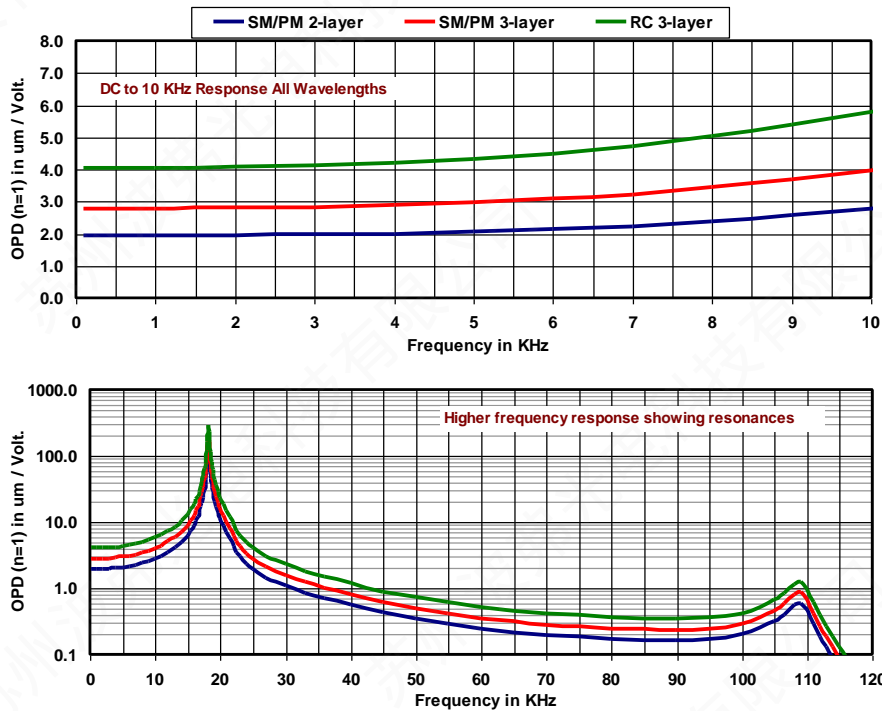

Large Signal = 70% of 1st Resonance Operation
Small Signal = Frequencies extending past resonance, but at reduced modulation levels

PZ3 Fiber Stretcher Models

Model	Description
PZ3-SMF2-O	Mid-range stretcher, 2-layer SMF28 fiber, bare leads, open, mounting kit
PZ3-SMF2-PC-E	Mid-range stretcher, 2-layer SMF28 fiber, FC/PC connectors, enclosed
PZ3-SMF2-APC-E	Mid-range stretcher, 2-layer SMF28 fiber, FC/APC connectors, enclosed
PZ3-SM2-O-XXX	Mid-range stretcher, 2-layer SM fiber, bare leads, open, mounting kit
PZ3-SM2-PC-E-XXX	Mid-range stretcher, 2-layer SM fiber, FC/PC connectors, enclosed
PZ3-SM2-APC-E-XXX	Mid-range stretcher, 2-layer SM fiber, FC/APC connectors, enclosed
PZ3-SMF3-O	Mid-range stretcher, 3-layer SMF28 fiber, bare leads, open, mounting kit
PZ3-SMF3-PC-E	Mid-range stretcher, 3-layer SMF28 fiber, FC/PC connectors, enclosed
PZ3-SMF3-APC-E	Mid-range stretcher, 3-layer SMF28 fiber, FC/APC connectors, enclosed
PZ3-SM3-O-XXX	Mid-range stretcher, 3-layer SM fiber, bare leads, open, mounting kit
PZ3-SM3-PC-E-XXX	Mid-range stretcher, 3-layer SM fiber, FC/PC connectors, enclosed
PZ3-SM3-APC-E-XXX	Mid-range stretcher, 3-layer SM fiber, FC/APC connectors, enclosed
PZ3-PM2-O-XXX	Mid-range stretcher, 2-layer PM fiber, bare leads, open, mounting kit
PZ3-PM2-PC-E-XXX	Mid-range stretcher, 2-layer PM fiber, FC/PC connectors, enclosed
PZ3-PM2-APC-E-XXX	Mid-range stretcher, 2-layer PM fiber, FC/APC connectors, enclosed
PZ3-PM3-O-XXX	Mid-range stretcher, 3-layer PM fiber, bare leads, open, mounting kit
PZ3-PM3-PC-E-XXX	Mid-range stretcher, 3-layer PM fiber, FC/PC connectors, enclosed
PZ3-PM3-APC-E-XXX	Mid-range stretcher, 3-layer PM fiber, FC/APC connectors, enclosed
PZ3-RC3-O-XXX	Mid-range stretcher, 3-layer RC fiber, bare leads, open, mounting kit
PZ3-RC3-PC-E-XXX	Mid-range stretcher, 3-layer RC fiber, FC/PC connectors, enclosed
PZ3-RC3-APC-E-XXX	Mid-range stretcher, 3-layer RC fiber, FC/APC connectors, enclosed

Designed for Bipolar Drive

Optiphase fiber stretchers are designed to operate with a bipolar voltage drive. This is unique capability offers significantly greater convenience when compared to other approaches that mandate unipolar operation only with an offset voltage drive.

How to drive PZ3 stretchers

The equivalent circuit for the PZ3 fiber stretcher is shown below. At frequencies sufficiently below the first resonance (dc - 10 KHz) the effective impedance is capacitive, defined by C0+C1+C2, being approximately 42 nF. At 10 KHz, the magnitude of the impedance of this capacitance is 400 ohms. Most laboratory equipment or circuitry can be used to drive this load with no modifications.

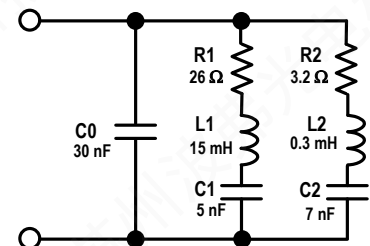

PZ3 Series Equivalent Impedance

DC - 10 KHz is approx C0 + C1 + C2 (= 42 nF)
First Resonance (18 KHz) defined by R1, C1, L1
Second Resonance (110 KHz) defined by R2, C2, L2

Part No. Designation and Fiber Types Used

λ range (nm):	780-900	950-1200	1260-1400	1450-1625
XXX =	850	980	131	155
Y = P for Panda; B for Bowtie				
SM/ SMF	Corning HI-80	Corning HI-80	Corning SMF28e+	
RC	NA	NA	Draka Elite 80 um BendBright-XS	
PM-Panda	Corning PM 850	Corning PM 980	Corning PM 1300	Corning PM 1550
PM-Bowtie	Fibercore HB800	Fibercore HB1000	Fibercore HB1250	Fibercore HB1500

Trademarks are property of their respective manufacturers.